



WATER HEATER FOR POOL & SPA

Now I am really taking advantage of my pool and spa

**MODEL C**  
**Electronic**



**USER'S GUIDE**

[www.valtherm.ca](http://www.valtherm.ca) | Tél. 514.262.5010 | Fax. 450.735.0935 | [info@valtherm.ca](mailto:info@valtherm.ca)

# TABLE OF CONTENT

- GENERAL CHARACTERISTICS
- WARNING
- HOW TO DETERMINE RATING KW
  - EMPIRICAL METHOD
  - MATHEMATICAL METHOD
- SIZE OF EXTERNAL WIRINGS AND BREAKER REQUIRED
- ESTIMATION OF OPERATIONAL COST
- INSTALLATION-LOCATIONAL COST
- START UP
- PLUMBING
- PLUMBING DIAGRAM
- IINSTRUCTIONS ON THE ELECTRONIC THERMOSTAT
- PHYSICAL DIAGRAM-EXTERNAL VIEW
- PHYSICAL DIAGRAM-INTERNAL VIEW
- ELECTRIC DIAGRAM OF ELECTRONIC THERMOSTAT
- ELECTRICITY
- WINTERIZING
- SAFETY
- TROUBLESHOOTING
- WARRANTY

## GENERAL CHARACTERISTICS

- ❖ Available models for above ground pools, built-in pools, whirl pools, indoor or outdoor pools.
- ❖ Maintenance free.
- ❖ Easy to install.
- ❖ Noiseless-without smell
- ❖ PVC tank-eliminating dirt due to rust
- ❖ Contains one thermal circuit breaker.
- ❖ Available power; 5kw, 10kw and 15kw
- ❖ Economical, this model is designed for indoor or outdoor installation. However, it is strongly recommended to install the heater inside or out of the sun exposure.
- ❖ Designed for above ground pools or built-in pools with 15000 gallons capacity.
- ❖ One year warranty on all parts except heating elements.
- ❖ Approved



## WARNING

- As like all pool heaters, VAL THERM must be filled of water when in operation. Risk of damage when used dry. Such damage is not covered by the warranty.  
  
Install heater below water level to ensure of a full tank.
- It is strongly recommended to install inside or out of the sun exposure.
- For safety purpose, the installation of your heater should always be done by a qualified electrician.
- Maintain proper water chemical balance: pH level: 7.4, Alkalinity: 120, salinity: 180-260, otherwise internal parts may deteriorate prematurely, those damages are not covered by the warranty. test the water and balance every week.
- For pool with salt machine : do not go over 3200 PPM, Titanium elements option.
- If you install a timer on the pump and/or the filter, there needs to be a 240 volts timer on the water heater do that this one shuts down 30 minutes before the one on the pump and/or filter.

## HOW TO DETERMINE THE RIGHT POWER RATING OF YOUR VALTHERM POOL HEATER

The following factors will influence the power needed for your pool heater: Pool dimension, average depth, wind exposure, period of utilization, ground composition, weather, etc...

With normal weather conditions as in our regions, we will be able to determine the power needed for your pool heater, based on empirical method or mathematical formulas.

### EMPIRICAL METHOD

Our experience shows that according to your utilization period, the power of your heater should be as follow:

- 4 months utilization: 1.0 kw per 4500 litres (1000 imperial gallons)
- 5 months utilization: 1.5 kw per 4500 litres (1000 imperial gallons)
- 6 months utilization: 2.5 kw per 4500 litres (1000 imperial gallons)

### MATHEMATICAL METHOD

You can determine your heater power and also weather elevation rate for a given heater by applying this formula:

- How to establish the heater power:

$$\text{Power (KW)} = \frac{K (\text{W}/^{\circ}\text{Cft}^2) \times \text{temp.diff. } (^{\circ}\text{C}) \times \text{surf pool. (ft}^2)}{1000 (\text{W/KW})}$$

K: Conversion constant: 5.715 W/°ft²  
 Temp. Diff.: Temperature spread between water surface and ambient air. Normal use is generally between 5°C and 8°C.

- How to determine temperature elevation rate:

$$\text{Elevation } (^{\circ}\text{C}/\text{hour}) = \frac{K (^{\circ}\text{Cft}^3/\text{KWH}) \times \text{Power (KW)}}{\text{Surf. pool (ft}^2) \times \text{av.depth (ft)}}$$

K:

**conversion constant : 15.3°Cft³/kWh**

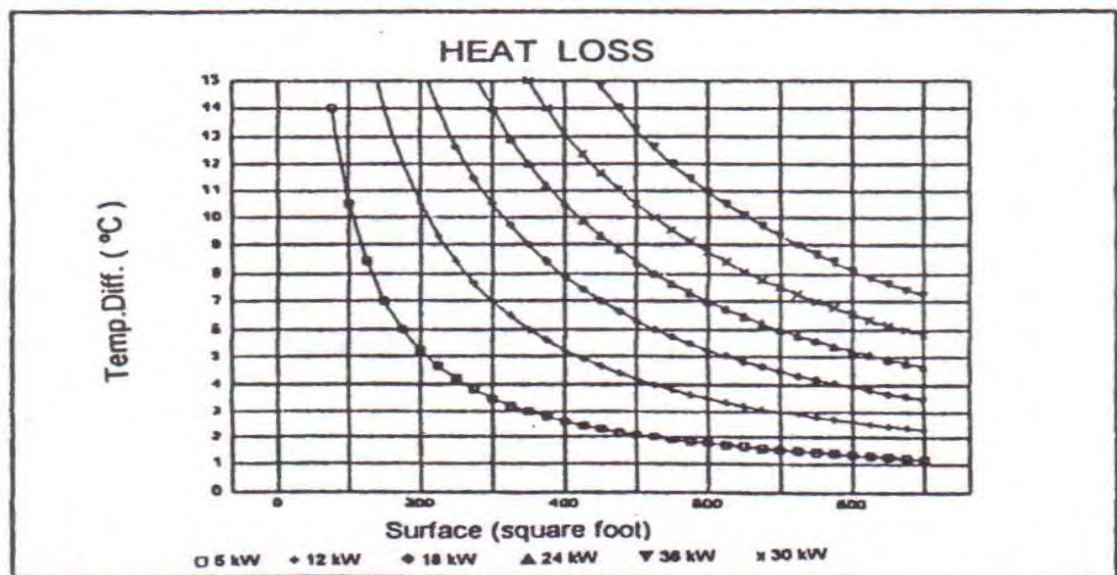

**Water heater power vs surface and temperature**

Rule of thumb: for each KW per 1000 gallons of water, you can add 1 F° of temperature elevation an hour.

Dimensions of pools	US Gallons	impérial Gallons	Liters	Elevation of temperature					
				5KW		5KW		5KW	
				°C/hour	°F/hour	°C/hour	°F/hour	°C/hour	°F/hour
Above ground									
15`	5 200	4 330	19 684	0.22	0.39	0.44	0.79	0.66	1.18
18`	7 600	6 328	28 769	0.15	0.27	0.30	0.54	0.45	0.81
21`	10 400	8 659	39 368	0.11	0.20	0.22	0.39	0.33	0.59
24`	13 500	11 240	51 102	0.08	0.15	0.17	0.30	0.25	0.46
27`	17 200	14 321	65 108	0.07	0.12	0.13	0.24	0.20	0.36
14` x 24`	7 700	6 411	29 147	0.15	0.27	0.30	0.53	0.44	0.80
15` x 25`	8 000	6 661	30 281	0.14	0.26	0.28	0.51	0.43	0.77
15` x 30`	12 000	9 991	45 424	0.09	0.17	0.19	0.34	0.28	0.51
Built-in									
4` x 28`	16 200	13 488	61 323	0.07	0.13	0.14	0.25	0.21	0.38
16` x 32`	21 100	17 568	79 871	0.05	0.10	0.11	0.19	0.16	0.29
18` x 36`	26 700	22 230	101 070	0.04	0.08	0.09	0.15	0.13	0.23
20` x 40`	33 000	27 476	124 918	0.03	0.06	0.07	0.12	0.10	0.19

- Heat losses by convection, conduction and radiation are not included when determining temperature elevation rate. The above figure can be used when difference in temperature between the water and the ambient air is 1°C. However, if that difference is more than 2°C, then the rate is higher than those shown on the figure. This is due to the loss of heat that the heater has to compensate before effectively increasing the temperature of the water.

### SIZE OF EXTERNAL WIRINGS AND BREAKER REQUIRED

Dimensions of pool	Gallons	Liters	Required pool heater	Line current*	BTU	Installation	
					Per HOUR	Breaker	Wires
Above ground							
15`	5 200	19 684	5KW	20.8A	17 060	30 A of more	#10
18`	7 600	28 769	10KW	41.7A	34 120	60 A of more	# 6
21`	10 400	39 368	10KW	41.7A	34 120	60 A of more	# 6
24`	13 500	51 102	15KW	62.5A	51 180	80 A of more	# 4
27`	17 200	65 108	15KW	62.5A	51 180	80 A of more	# 4
14` x 24`	7 700	29 147	10KW	41.7A	34 120	60 A of more	# 6
15` x 25`	8 000	30 281	10KW	41.7A	34 120	60 A of more	# 6
15` x 30`	12 000	45 424	15KW	62.5A	51 180	80 A of more	# 4
Built-in							
14` x 28`	16 200	61 323	15KW	62.5A	51 180	80 A of more	# 4
16` x 32`	21 100	79 871	21KW	87.5A	71 652	110 A of more	# 4
18` x 36`	26 700	101 070	24KW	100.0A	81 888	125 A of more	# 3
20` x 40`	33 000	124 918	30KW	125.0A	102 360	160 A of more	# 0

\*For 240 volts application, 1 phase

Note :

- Many factors influence the choice of the capacity of a pool heater (area of the pool, average depth, duration of the period of utilization, external temperature, etc...).
- Required KW, if being used for 4 months/year : 1.0KW per 1000 gallons of water
- Required KW, if being used for 5 months/year : 1.5KW per 1000 gallons of water

# HOW TO DETERMINE THE COST OF THE VAL-THERM POOL HEATER

Formula : proposed KW X n Hours of operation X cost kWh\*

\*kWh = kW X hours (consumption in kilowatt-hour)

Example: if the required pool heater power is 10kw. In operation for 10 hours/days, and the cost per Kw is 0.0731¢ (2011 domestic rate in Quebec). Then the daily cost would be:

- 10Kw X 10 hours/day X 0.0731¢
- 100kWh = 7.31\$ per day

## INSTALLATION - LOCATION SITE

This Val Therm, water heater can be installed either. However, we strongly recommend installing the pool heater inside. It is important that all safety and installation standards be respected.

The water heater must be positioned vertically at the filter end. Free space of left space of about 18'' on top of it should be left for maintenance purpose.

When installing, it is recommended to install a bypass.

The connection of the plumbing must be installed by professional.

Put the water heater the last one on the line before the return of water.

## STAR UP

- 1- Before switching on pool heater, activate the pump of the filter and ensure that no air remains inside the water heater. This can be checked when no more bubbles appear at the pool when water recycles back to the surface.
- 2- Adjust the thermostat to the desired temperature level. The time to reach the desired temperature varies, depending on initial temperature of the water, weather conditions, etc...

For security, one reset button protect the machine against high temperature elevation 120 C°, the reset button shut off automatically the circuit, so you have to restart by pushing the red button. The second security, It's a pressure switch for the lower water pressure in the water tank. This unit require a minimum flow of 35 gallons per minute.

- 3- Maintain proper water chemical balance: pH level: 7-4, alkalinity: 120, salinity: 180-260, otherwise internal parts may deteriorate prematurely, those damages are bit covered by the warranty. Test the water and balance it every week.
- 4- Tank should be full of water before starting up, otherwise permanent damage to parts occurs. Such damage is not covered by the warranty.

## PLUMBING

The inlet and outlet of the pool heater are connected to two 1 ½'' N.P.T. Drain plug needed ½'' N.P.T.

Note: Use only Teflon tape to assure water tightness of pipes connections. Be careful not to over TITS the fitting because it can crack-will not be cover by warranty

## PLUMBING SKETCH FOR THE WATER HEATER MODEL C

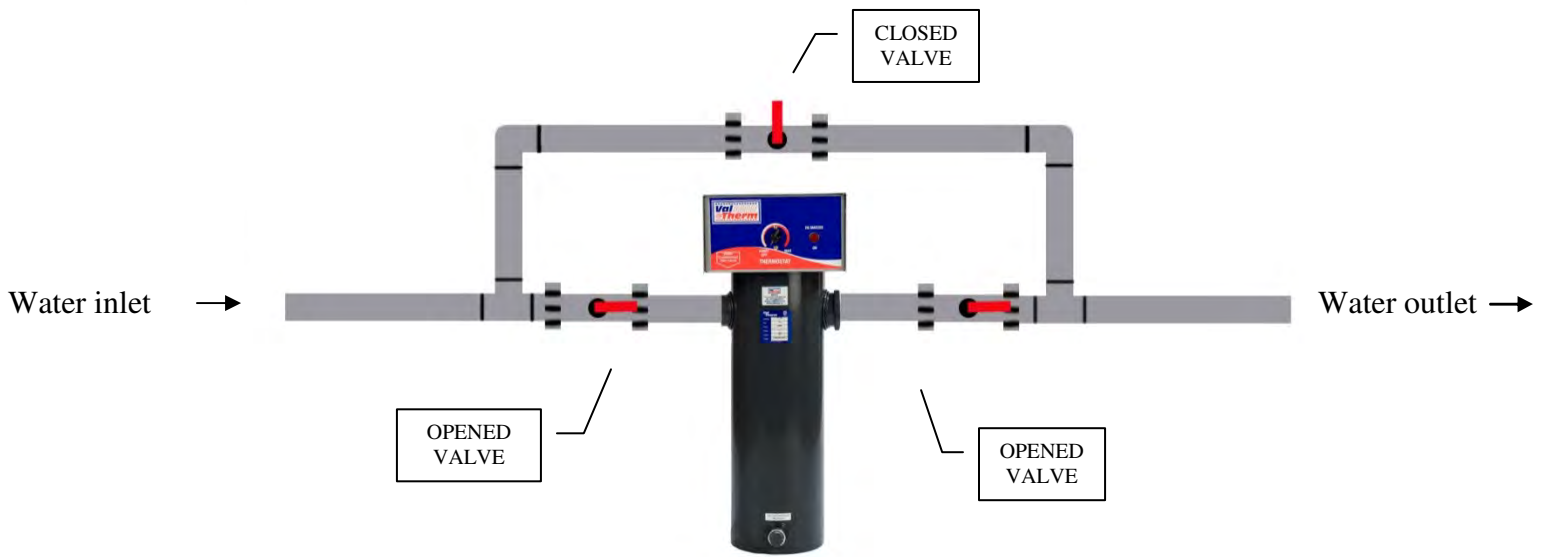

### DEVIATION

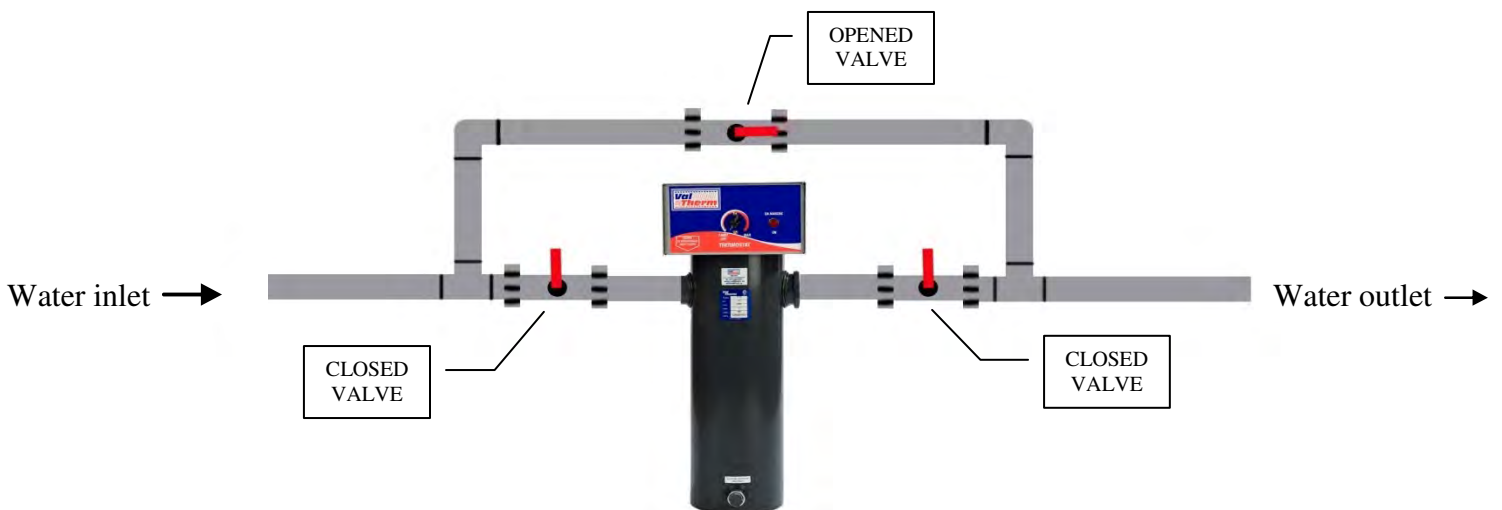

**It is recommended to install a by-pass on the plumbing of the water heater.**

**It is recommended to isolate your water heater on the water by pass when you do your shock treatment at the opening of you pool not to damage the component.**

# Instructions on the electronic thermostat

## Model A and C



- Display of actual temperature.

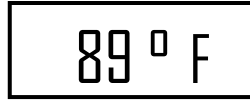

- Choice of Celsius or Fahrenheit: Press on both arrows at the same time.



- Choice of either pool mode (88 F max) or spa mode (104 F max) : Press button and at the same time the up and down arrows to change.



- Codes on the display :

- ✚ **PO** : indicates that the temperature has surpassed 110 F, it will shut down for thermal protection.
- ✚ **AL** : if PO was indicated but temperature has decreased 110 F, the unit will stay blocked on alarm mode and the screen will read AL. To unblock alarm, press on one of the up and down buttons and then a U will appear for a couple of seconds and finally it will return to normal, displaying the current temperature as before the alarm went off.
- ✚ **PSI** : indicates lack of water pressure in the heat pump. At this moment, the heat pump has stopped. Verify all valves of the pipes or the pressure in the tank.
- ✚ **LO**: Problem with sounding line. The water might be too cold; the water temperature reading on the digital thermostat starts at 65°C, if the warning lights are lit ( : ), that means your water heater is functioning.

- Warning light : (red button  on left side of the temperature display, see above image)

- Heating mode: Warning light indicates that heat pump is in heating mode.
- Economic mode: Warning light indicates that the heat pump is in economical mode by converting the temperature to maintain hot water in water bassin.



# PHYSICAL DIAGRAM – EXTERNAL VIEW



**\*\*OPTION ELEMENT TITANIUM FOR MACHINE WITH SALT**

# PHYSICAL DIAGRAM - INTERNAL VIEW

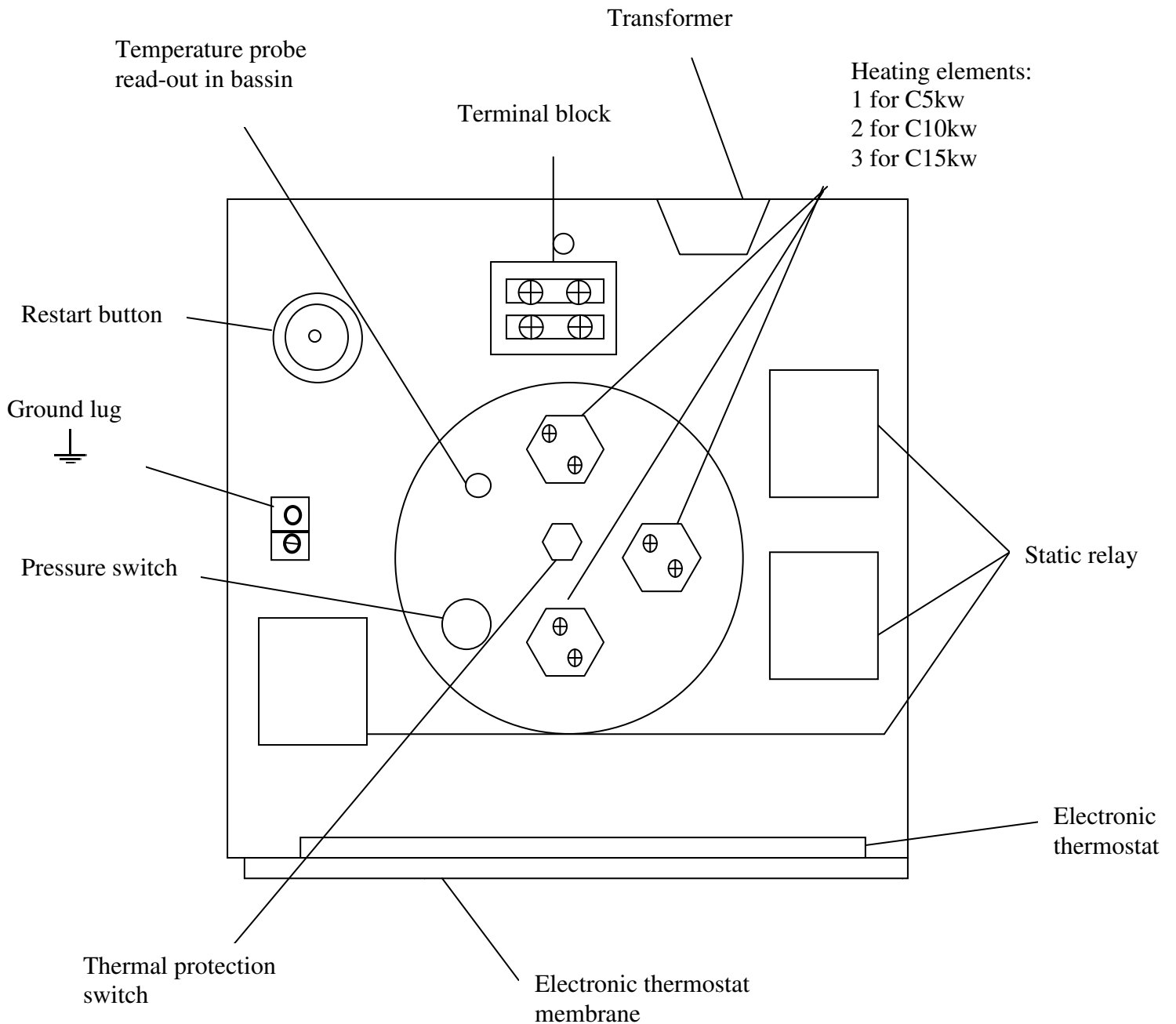

# Electric diagram of electronic thermostat

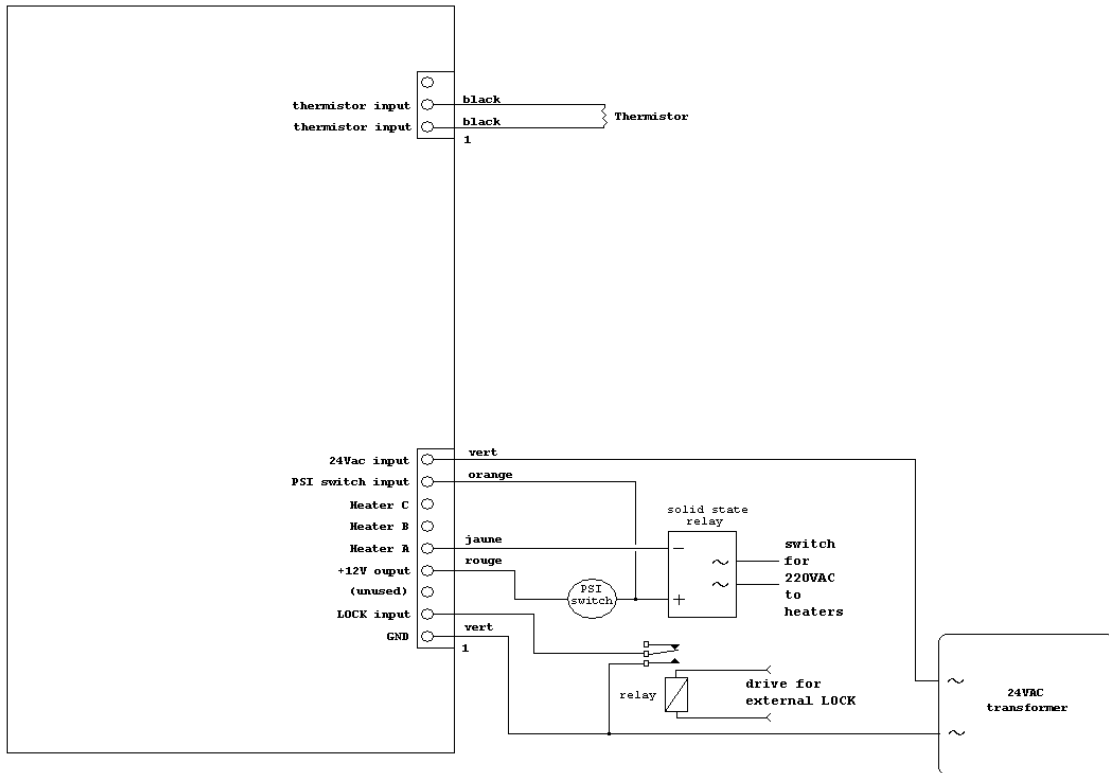

# Model C ELECTRIC DIAGRAM "electronic"

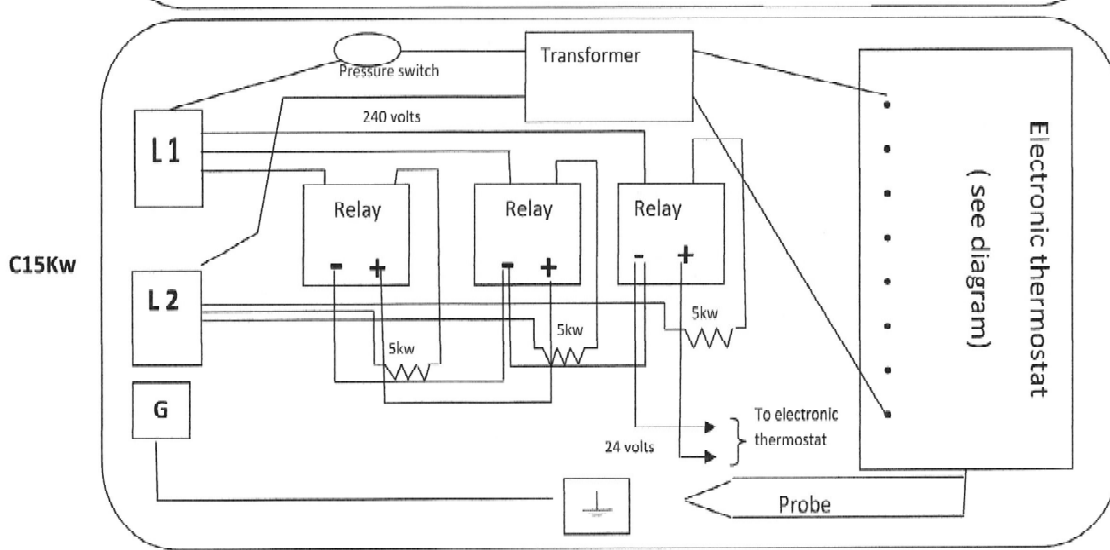
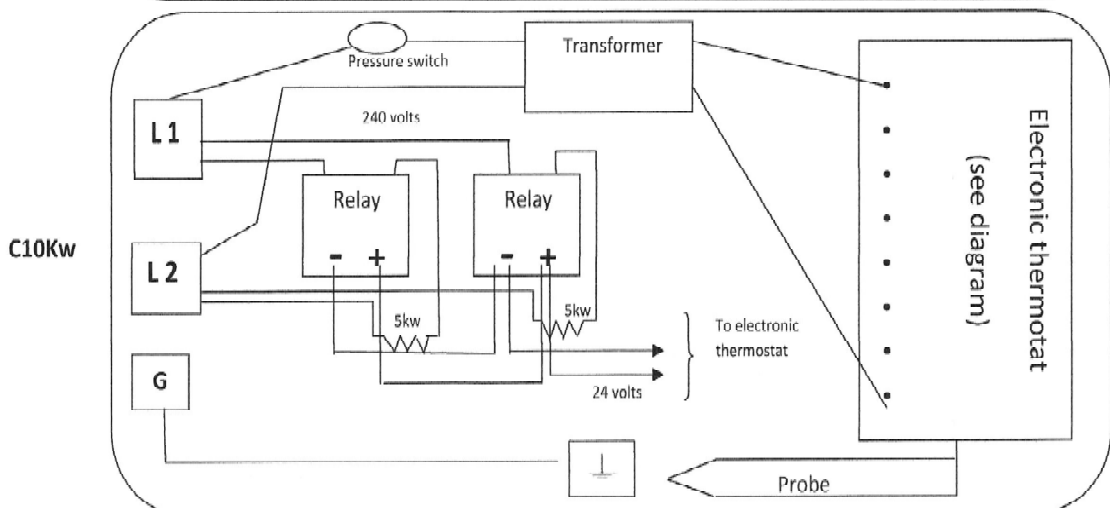
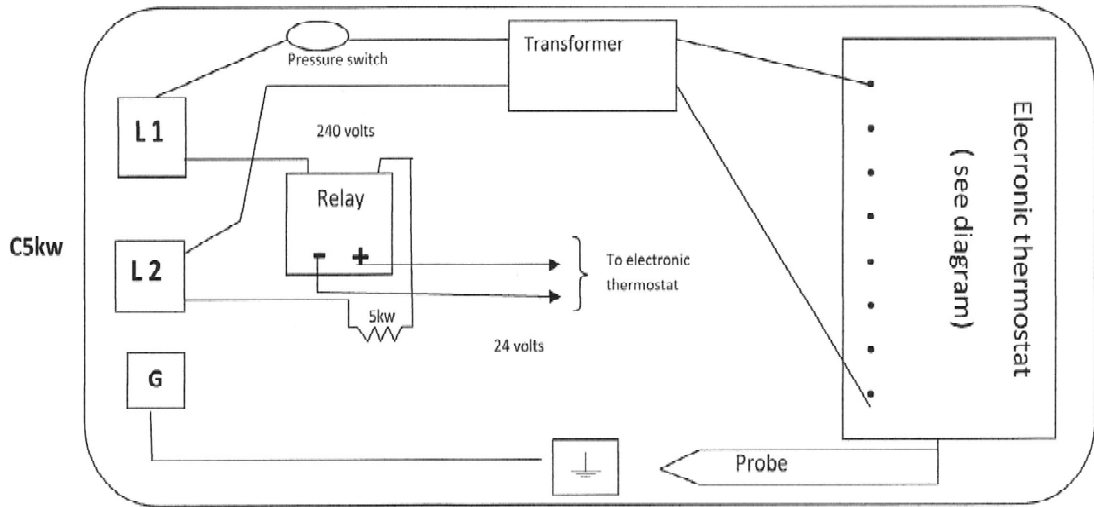

# WINTERIWING

Empty heater tank draining plug to prevent water freezing inside tank during winter.

## SAFETY

Before opening the pool heater, make sure it is not plugged in.

This unit require a minimum flow of 35 gallons per minute.

Part replacement with original only

Do not install two heaters on the same line because it could lower the water pressure and cause damage.

## TROUBLESHOOTING

If water stays cold and pilot light is off:

- 1- Check the voltage
- 2- Check circuit breaker, main fuses and replace if necessary
- 3- Check the “High Temperature Cut-off Switch with Manual Reset” (refer to the physical diagram).
- 4- Check thermostat.

If water does not heat as wanted and pilot light is on:

- 1- Check voltage
- 2- Check thermostat
- 3- Check heating elements. You should obtain the following readings in regards of elements type:

### Electrical characteristics of Heating Elements

TYPE	Puissance (KW)	Voltage L-L (V)	Courant Ligne (A)	Résistance (Élément débranché)
240v-1ph	5,0	240	20,8	11,5

# WARRANTY

THIS WATER HEATER IS QUARANTIED FOR ONE (1) YEAR AGAINST MANUFACTURING DEFAULT (EXEPT HAETING ELEMENTS).

ANY DEFECTIVE UNIT WILL BE RETURNED, PREPAID, TO US FOR REPAIRS. VAL THERM IS NOT RESPONSIBLE FOR THER REMOVAL AND REINSTALLATION OF SUCH UNIT.

CUSTOMER NAME: \_\_\_\_\_

ADDRESS : \_\_\_\_\_

DEALER NAME : \_\_\_\_\_

---

Water heater:      Pool ( )      SPA ( )

Capacity (kw) : \_\_\_\_\_

Model: \_\_\_\_\_

Serial number : \_\_\_\_\_

## IMPORTANT:

Warranty is void if the following conditions are not met:

- Before starting up, tank must be filled or water. Otherwise, permanent damage may occur to parts.
- Maintain proper water chemical balance: pH level: 7.4, alkalinity: 120, salinity: 180-260. Otherwise internal parts may deteriorate prematurely. Test the water and balance it every week.
- For pools or spas with salt machine: do not go over 3200 PPM, TITANIUM ELEMENTS OPTION FOR SALT SYSTEMS
- Do not put chlorine tablets in the skimmer.
- Do not send water through the water heater until it is balanced (see bypass diagram).
- If you install a timer on the pump and/or the filter, there needs to be a 240 volts timer on the water heater do that this one shuts down 30 minutes before the one on the pump and/or filter.